



PUBLIC POOL & SPA RESURFACING / EQUIPMENT CHANGE / FENCING APPLICATION

NAME OF POOL: _____

POOL ADDRESS: _____

OWNER: _____ **PHONE:** _____

ADDRESS: _____

DESIGNER (IF APPLICABLE): _____

ADDRESS: _____ **PHONE:** _____

POOL CONTRACTOR (IF APPLICABLE): _____

ADDRESS: _____ **PHONE:** _____

TYPE OF APPROVAL: Resurfacing Equipment Change Fencing VGB

TYPE OF POOL: Standard Spa Wading Other

SPECIFY DETAILS (i.e., type of equipment to be changed, type of pool if other, etc.): _____

INSTRUCTIONS FOR SUBMITTING PLANS

Plans are approved in the order they are received. Missing information or improperly prepared plans will delay the approval process.

- Submit this completed application with three sets of plans and required materials, as specified in the application guidelines. For any new equipment, you must include the manufacturer's specification sheet. For a new pump, the specification sheet must include a pump curve.
- Submit the appropriate plan review fee. Depending on the scope of work, some projects may be billed at an hourly rate, at a minimum of two hours.
- Environmental Health Services may require the submission of additional information as required to determine the compliance of plans and specifications submitted for approval.
- Pool plan approval does not authorize the violation of any ordinance or regulation. Final approval is subject to field inspection and evaluation.

For Office Use Only:				
Fee Paid \$ _____	Receipt # _____	Check # _____	Date _____	Rec'd by _____

PLANCHECK GUIDELINES AND REQUIREMENTS

- 1) Swimming pool shells must be white in color. Spa pools may be light pastel colors with a light reflectance value of 55% or more. All materials other than plaster must be submitted to this Department for approval.
- 2) When a pool is replastered/resurfaced, all pools greater than five feet in depth are required to have a 4-inch wide straight line of slip-resistant contrasting tile along the floor of the pool where the water depth is 4½ feet. Unglazed tile is considered slip-resistant.
- 3) Remove any illegal projections in the pool wall (e.g., projections that stick out more than 1¼ inches such as sweep attachments).
- 4) Provide depth markers at both sides of a swimming pool at the shallowest and deepest depths, at all breaks in slope, and at both ends of the pool. Spas must have a minimum of two depth markers. Water depth is measured from the floor of the pool to the middle of the tile line. Markers should indicate depth to the nearest six inches. If a pool exceeds 20 feet in width, additional markers are required on the edge of the deck next to the pool.
- 5) All skimmers must properly work or be replaced (commercial grade only). The equalizer lines on the skimmers should remain open after the plastering work. Provide approved anti-hair entrapment covers for equalizer openings.
- 6) All main drain covers must be in good repair, meet ANSI standards, be VGB compliant, and be secured so as to be removable only with tools.
- 7) Replace any missing inlet fixtures.
- 8) Replace any missing tiles or grout and secure loose coping. Coping that is being replaced must extend over the pool wall 1 to 2 inches and may not be thicker than 2½ inches.
- 9) Provide a safety handrail over all stairs extending from the deck to the bottom step tread. The upper railing surface must be between 28 – 36 inches, as measured from the pool deck and the edge of each step tread to the railing. (see attached diagram)
- 10) Repair any cracked decking and eliminate all tripping hazards/uneven deck surfaces.
- 11) Repair/replace the pool lighting as needed, ensuring all lighting is approved and protected by ground fault circuit interrupters. Pools used at night shall be equipped with underwater light fixtures that will provide complete illumination to all underwater areas of the pool.
- 12) Indoor/outdoor carpeting or similar products are not approved for swimming or spa pool decks. This Department must approve any deck material other than concrete.
- 13) Install **recessed** rope anchors.
- 14) Install vacuum port covers that can **ONLY** be removed with a tool.

APPROVED HANDRAIL CONFIGURATION

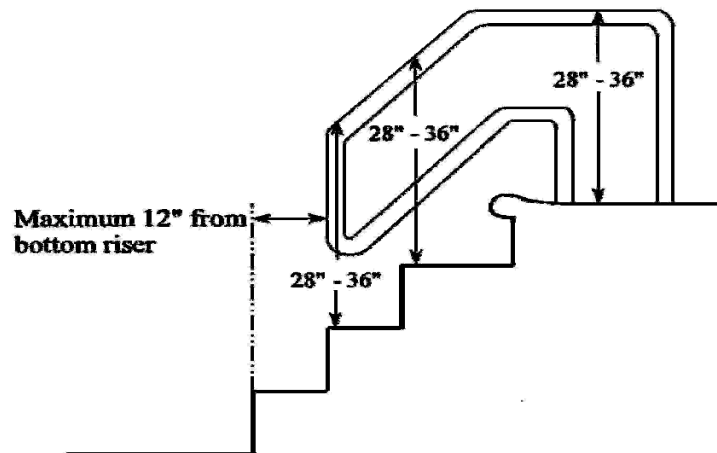
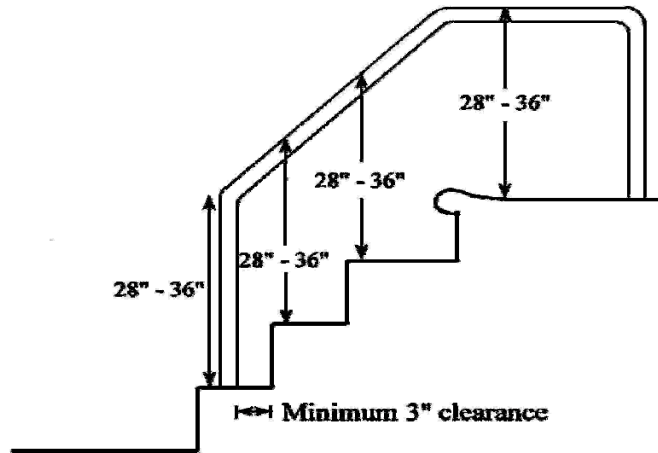

APPROVED POOL ENCLOSURE FENCING

